

Technical specifications

MASTER MPS

10 to 80 kVA THREE-PHASE INPUT / THREE-PHASE OUTPUT

10 to 100 kVA THREE-PHASE INPUT / SINGLE-PHASE OUTPUT

On Line Double Conversion (VFI) Technology with Isolated Inverter



CONTENTS

1.	PURPOSE.....	3
2.	SYSTEM DESCRIPTION	3
3.	REFERENCE STANDARDS.....	6
4.	APPLICATIONS.....	7
5.	CONFIGURATIONS.....	8
6.	UPS DESCRIPTION.....	12
6.1.	AC/DC Converter.....	13
6.1.1.	Easy Source.....	14
6.1.2.	Battery Care System.....	15
6.2.	DC/AC Converter.....	16
6.3.	Static Switch.....	17
7.	CONTROL PANEL	19
8.	SWITCHES.....	22
9.	COMMUNICATION.....	23
9.1.	Report signals.....	23
9.2.	Commands.....	23
9.3.	Emergency shutdown	23
9.4.	Monitoring and control software.....	23
10.	UPS CABINET	24
11.	INSTALLATION	24
12.	OPTIONS.....	24
12.1.	Communication	24
	<i>For the full and updated list of accessories please see the website www.riello-ups.com</i>	<i>27</i>
12.2.	Graphic remote panel.....	28
12.3.	Battery cabinets	28
12.4.	Start-up from battery (Cold Start).....	29
12.5.	UGS - UPS Group Synchroniser	29
12.6.	PSJ - Parallel Systems Joiner	30
12.7.	Isolation transformers.....	30
12.8.	Kit for UPSs without input and output neutral.....	30
12.9.	Protection levels	30
12.10	Faulty fan control.....	30
13.	ENVIRONMENTAL REQUIREMENTS.....	31
14.	TECHNICAL DATA THREE PHASE INPUT / THREE PHASE OUTPUT	32
15.	TECHNICAL DATA THREE PHASE INPUT/ SINGLE PHASE OUTPUT.....	38

1. PURPOSE

These technical specifications describe an Uninterruptible Power System (UPS), a device which supplies clean energy to the connected load, without any interruption due to disturbances in the mains power supply, including a total power failure.

MASTER MPS is a series of UPSs designed entirely by RIELLO UPS a leading manufacturer of uninterruptible power supplies from 350VA to 800kVA, with over 25 years of experience in the sector. To find out about the other products available, visit www.riello-ups.com.

2. SYSTEM DESCRIPTION

The present technical specification describes the technical features of the **MASTER MPS** series for the models with **three phase input, three phase output and three phase input, single phase output with rating 10, 15, 20, 30, 40, 60, 80 and 100 kVA**. MASTER MPS is with On Line double conversion technology accordance to VFI-SS-111 classification – as defined by standard IEC EN 62040-3 - with transformer in output downstream the inverter.

MASTER MPS is compatible with the most critical industrial installations thanks to its many features, such as:

- a) Easy source
 - Low distortion of the input voltage up to 3 % and power factor up to 0.95;
 - Compatibility with the motor generator thanks the functions as power walk-in, power walk-in delay timer and battery inhibition.
- b) Battery Care System
 - Battery recharge with two voltage levels as per characteristics $IU_1 U_2$;
 - Voltage Recharge with temperature compensation;
 - Compatibility to recharge battery with long autonomy;
 - Battery test to check a battery decay.
- c) Output nominal Power with Power Factor of 0,9
- d) Isolation transformer downstream the inverter to protect the load from mains interference in all operating conditions.
- e) Double protection of the load when powered in battery mode: the first protection is the usual one provided by the integrated electronic control and a second further protection is given by galvanic isolation of the inverter output transformer
- f) Thermal overrating of the inverter to guarantee an overload (kVA) at 110% for 60 minutes

- g) Backfeed protection
- h) System expandability up to 8 units, Dual BUS and Dynamic Dual Bus systems

The **Master MPS** range comprises the following models:

MODEL	DESCRIPTION
MPM 10	UPS 10kVA,6 Pulse, Three phase input /Single Phase Output
MPM HC 10	UPS 10kVA,6 Pulse, Three phase input /Single Phase Output with input harmonic filter
MPM 15	UPS 15kVA,6 Pulse, Three phase input /Single Phase Output
MPM HC 15	UPS 15kVA,6 Pulse, Three phase input /Single Phase Output with input harmonic filter
MPM 20	UPS 20kVA,6 Pulse, Three phase input /Single Phase Output
MPM HC 20	UPS 20kVA,6 Pulse, Three phase input /Single Phase Output with input harmonic filter
MPM 30	UPS 30kVA,6 Pulse, Three phase input /Single Phase Output
MPM HC 30	UPS 30kVA ,6 Pulse, Three phase input /Single Phase Output with input harmonic filter
MPM 40	UPS 40kVA,6 Pulse, Three phase input /Single Phase Output
MPM HC 40	UPS 40kVA,6 Pulse, Three phase input /Single Phase Output with input harmonic filter
MPM 60	UPS 60kVA,6 Pulse, Three phase input /Single Phase Output
MPM 60 HC	UPS 60kVA,6 Pulse, Three phase input /Single Phase Output with input harmonic filter
MPM 80	UPS 80kVA,6 Pulse, Three phase input /Single Phase Output
MPM 80 HC	UPS 80kVA,6 Pulse, Three phase input /Single Phase Output with input harmonic filter
MPM 100	UPS 100kVA,6 Pulse, Three phase input /Single Phase Output
MPM 100 HC	UPS 100kVA,6 Pulse, Three phase input /Single Phase Output with input harmonic filter

MODEL	DESCRIPTION
MPT 10	UPS 10kVA, 6 pulse, three phase input/three phase Output
MPT 10 HC	UPS 10kVA, 6 pulse, three phase input/three phase Output with input harmonic filter
MPT 15	UPS 15kVA, 6 pulse, three phase input/three phase Output
MPT 15 HC	UPS 15kVA, 6 pulse, three phase input/three phase Output with input harmonic filter
MPT 20	UPS 20kVA, 6 pulse, three phase input/three phase Output
MPT 20 HC	UPS 20kVA, 6 pulse, three phase input/three phase Output with input harmonic filter
MPT 30	UPS 30kVA, 6 pulse, three phase input/three phase Output
MPT 30 HC	UPS 30kVA, 6 pulse, three phase input/three phase Output with input harmonic filter
MPT 40	UPS 40kVA, 6 pulse, three phase input/three phase Output
MPT 40 HC	UPS 40kVA, 6 pulse, three phase input/three phase Output with input harmonic filter
MPT 60	UPS 60kVA, 6 pulse, three phase input/three phase output
MPT 60 HC	UPS 60kVA, 6 pulse, three phase input/three phase output with input harmonic filter
MPT 60 D	UPS 60kVA, 12 pulse, three phase input/three phase output
MPT 60 DHC	UPS 60kVA, 12 pulse, three phase input/three phase output with input harmonic filter
MPT 80	UPS 80kVA, 6 pulse, three phase input/three phase output
MPT 80 HC	UPS 80kVA, 6 pulse, three phase input/three phase output with input harmonic filter
MPT 80 D	UPS 80kVA, 12 pulse, three phase input/three phase output
MPT 80 DHC	UPS 80kVA, 12 pulse, three phase input/three phase output with input harmonic filter

The differences between the **HC**, **D** and **DHC** versions are found essentially in their input characteristics (harmonic currents and power factor).

See the Technical Data at the end of these specifications for further details.

3. REFERENCE STANDARDS

RPS SpA is a company certified ISO 9001 (Certificate No CERT-04674-99-AQ-VEN-SINCERT) and covers all procedures, operating methods and monitoring of all stages from design to production and sales activities.

This certification is a guarantee for the customer with regard to the following aspects:

- use of quality materials;
- meticulousness in the production and testing phases;
- constant customer support.

Besides company certification, the product is classified VFI-SS-111 in conformity with standard IEC EN 62040-3 and satisfies the following UPS specific standards:

- **EN62040-1** - Uninterruptible power systems (UPS): General and safety requirements;
- **EN 62040-3** - Methods of specifying the performance and test requirements;
- **EN 62040-2** - Electromagnetic compatibility.

The **Master MPS** series also makes reference to the following general standards, where applicable:

- IEC 60529: Degrees of protection provided by enclosures;
- IEC 60664: Insulation for equipment within low-voltage systems;
- IEC 60755: General requirements for residual current operated protective devices;
- IEC 60950: General safety requirements for Information Technology equipment;
- IEC 61000-2-2: Electromagnetic compatibility immunity;
- IEC 61000-4-1: Electromagnetic compatibility – overview of the IEC 61000-4 series;
- IEC 61000-4-2: Electrostatic discharge immunity test;
- IEC 61000-4-3: Radio-frequency, electromagnetic immunity test;
- IEC 61000-4-4: Electrical fast transients/burst immunity test;
- IEC 61000-4-5: Surge immunity test;
- IEC 61000-4-6: Test for immunity to conducted disturbances induced by radio frequency fields;
- IEC 61000-4-8: Power frequency magnetic field immunity test;
- IEC 61000-4-11: Voltage dips, short interruptions and voltage variations immunity test.

European Directives:

LV 2006/95/EC replace LV 73/23/EC and 93/68/EC

Low voltage Directive: contains provisions relating to equipment safety and imposes the EC marking obligation from 1/1/97.

EMC 2004/108/EC

Electromagnetic compatibility directive: covers the immunity and emission aspects of the UPS in its installation environment and imposes the obligatory use of CE marking as from 1/1/96.

4. APPLICATIONS

The UPSs of the **MASTER MPS** series are suitable for all applications requiring protection of the critical load, from simple installations to more complex systems where a higher level of reliability and maintainability is required.

Data Centres and Telecommunications: the uninterruptible power system can grow together with your business since the basic system can be expanded with up to eight units connected in parallel without compromising the initial investment. Furthermore, greater levels of reliability and maintainability can be achieved with the more advanced configurations such as the "Dual Bus" and "Dynamic System Expansion".

Industrial processes and electro-medical systems: the UPS is particularly suitable for application with industrial processes and the power supply to electro-medical systems, thanks to its design principles and technical features, such as for example:

- inverter with output transformer guaranteeing isolation of the load from mains interference in all conditions;
- high short circuit and overload capacity;
- high battery recharging capacity, enabling applications with different kinds of batteries (sealed, vented or Nickel Cadmium) with long back-up time.

Emergency systems: the Stand-by OFF mode of operation can be selected to activate the emergency back-up function, as defined by standard EN 50171 (Central Power Supply Syst

5. CONFIGURATIONS

The following configurations are available:

Single UPS

The single version of the system, normally used for simple installations. The same system can function as a frequency converter, 50/60Hz and vice versa, with or without battery by means of a simple setting that can be effected in situ.

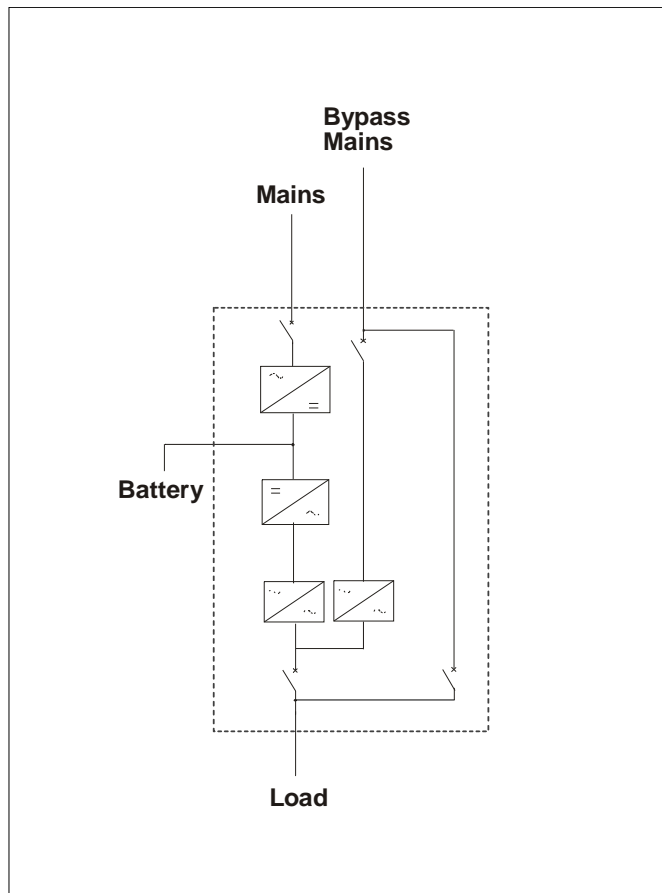

Parallel configuration

Up to 8 UPSs can be connected in parallel to increase the power of the uninterruptible power system (power parallel) or to enhance its reliability (redundant parallel). The system is defined as “redundant parallel” when the stoppage of one or several UPSs does not determine the loss of the power supply.

All the UPSs power the load simultaneously with automatic sharing of the current.

The units exchange information on the operating status and the sync signals by means of the RS485 connections in loop with dual redundancy. This means that even in the event of the accidental interruption of both connections, only the UPS affected by this interruption cuts itself off, while the other one continues to operate without any interference.

The “**Hot System Expansion**” feature means that a new UPS can be added to the system while the other units are on-line and powering the load from the inverter. The integrated UPS will configure itself automatically with the system data without any disturbance to the load.

In configurations with more than two units, it is recommended to install an external maintenance bypass and to inhibit the one inside the UPS, in order to improve service operations.

The parallel system may function with a separate battery or a single battery, that is, one battery shared by several UPSs.

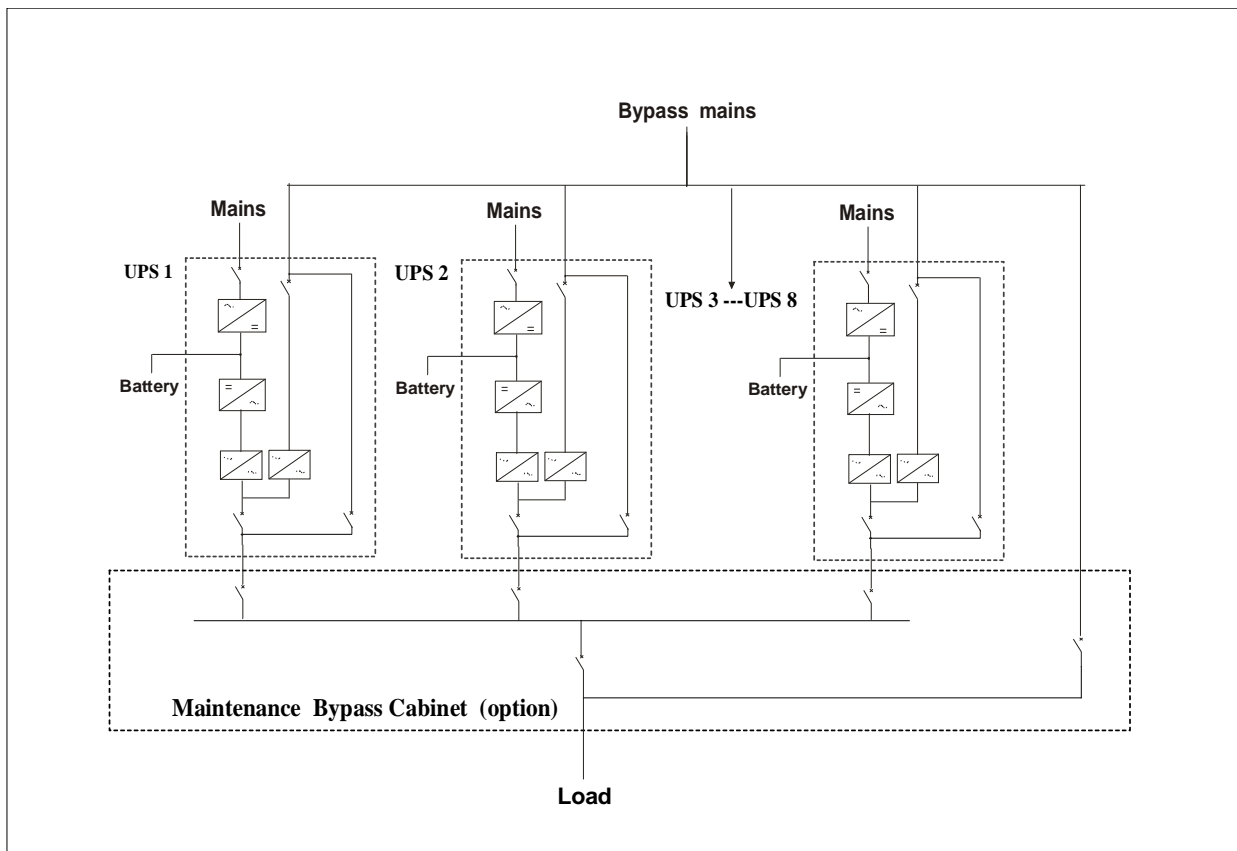

Dual Bus System (UGS)

Two independent systems can be configured in Dual Bus with a single or separate power source. The synchronisation option (UGS) keeps the outputs of the two systems constantly synchronised, regardless of the input variations and when the system is powered by the battery.

Each system comprises up to a maximum of 4 parallel UPSs.

This system has been designed for configurations that use the STS (Static Transfer Switch) since it guarantees switching from one continuous source to the other without disturbances to the loads.

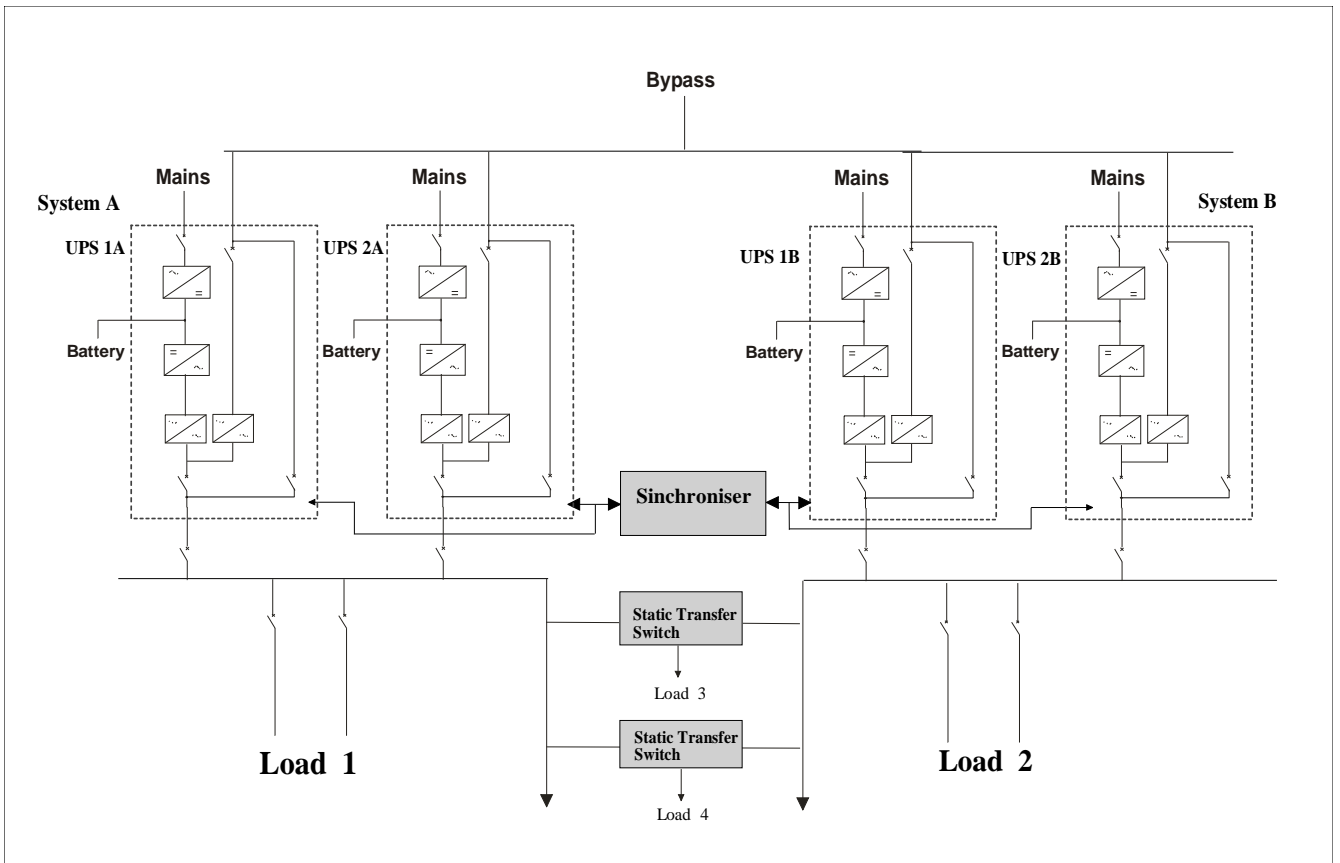

Dynamic Dual Bus System (PSJ)

Two independent systems (up to 4 units each) can be connected in a “Dynamic Dual Bus” configuration by means of the PSJ (Parallel System Joiner) option.

This enables the two systems to be joined to form a single system when, for example, part of one system is undergoing maintenance and it is felt appropriate to use the redundant UPS for both bars of the load.

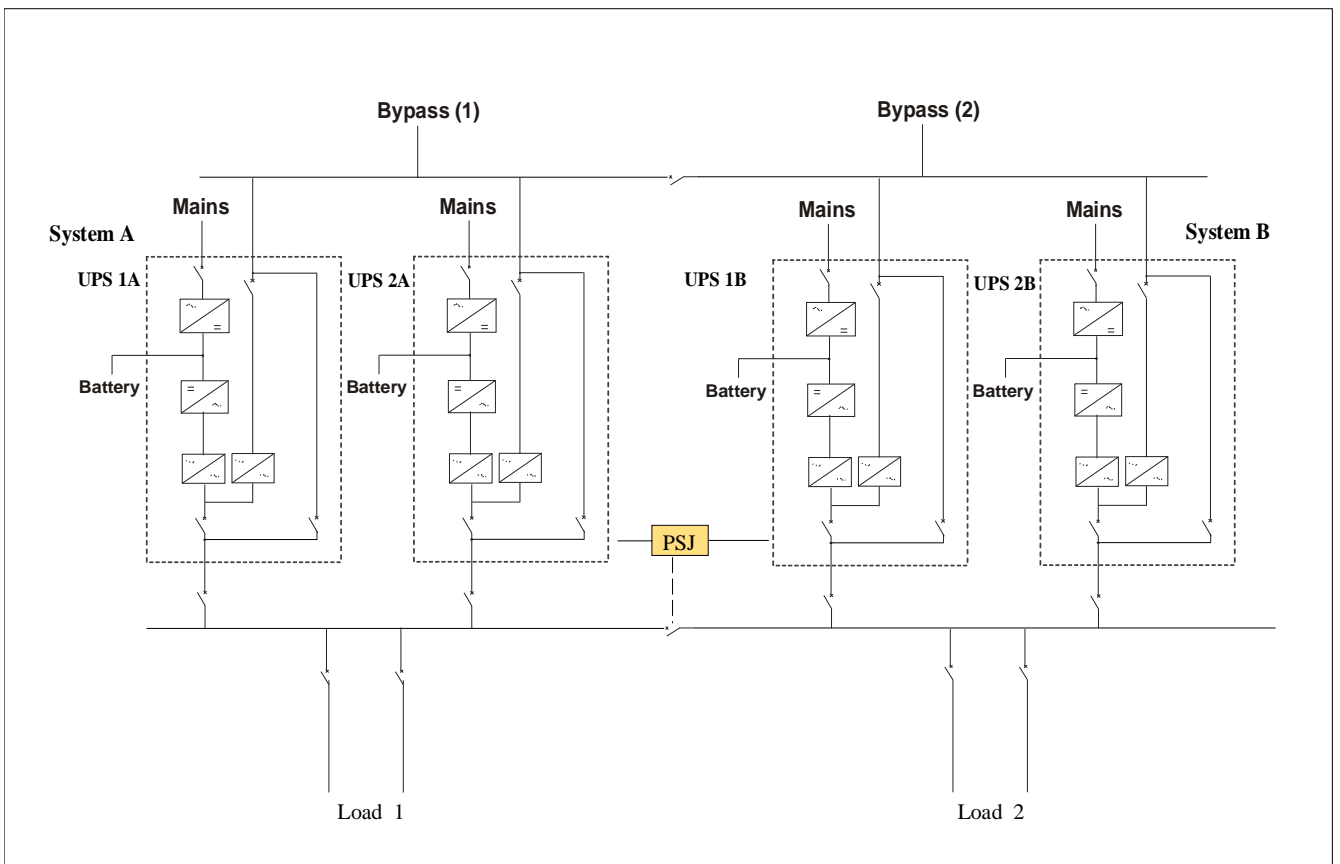

6. UPS DESCRIPTION

The uninterruptible power supply can be set to operate in four operating modes: ON-LINE, STAND-BY ON, SMART ACTIVE and STAND-BY OFF.

Mode: ON-LINE

Normal: The rectifier draws energy from the mains to power the inverter and keep the batteries charged; the inverter powers the load with voltage and frequency stabilised and in sync with the emergency mains, if appropriate.

Emergency: when the mains power supply goes out of the pre-set limits, the rectifier switches off and the inverter is powered from the battery for the envisaged back-up time without any disturbance to the load. When the mains power supply is restored, the Rectifier starts to operate gradually (power walk in), powering the batteries again and charging the inverter.

Overload: in the event of an inverter overload beyond the envisaged limits, or a manual shutdown, the load is automatically transferred onto the emergency mains by means of the Static switch without any disturbance to the load.

Mode: STAND-BY ON

The load is normally powered from the emergency mains, the rectifier keeps the batteries charged. When the mains goes outside the preset range, the load is transferred automatically onto the inverter until the mains returns to a suitable level.

This mode is suitable for powering loads that are not sensitive to mains interference, thus allowing increased system efficiency of up to 98%.

Mode: SMART ACTIVE

When the **MASTER MPS** system is configured in SMART ACTIVE mode, it automatically determines whether to operate in ON-LINE or STAND-BY ON mode.

This is done by monitoring the emergency mains: if this remains suitable for a defined period, the system sets itself to STAND-BY ON mode; otherwise it remains in ON-LINE mode.

Mode: STAND-BY OFF

When the mains power supply is present, the rectifier keeps the batteries charged and the inverter is switched off. When the mains fails, the rectifier switches off and the inverter is activated in approx. 200 ms, using the battery energy.

This application is suitable for the power supply of emergency lighting, as defined by standard EN 50171.

The block diagram of the **MASTER MPS** system is shown below:

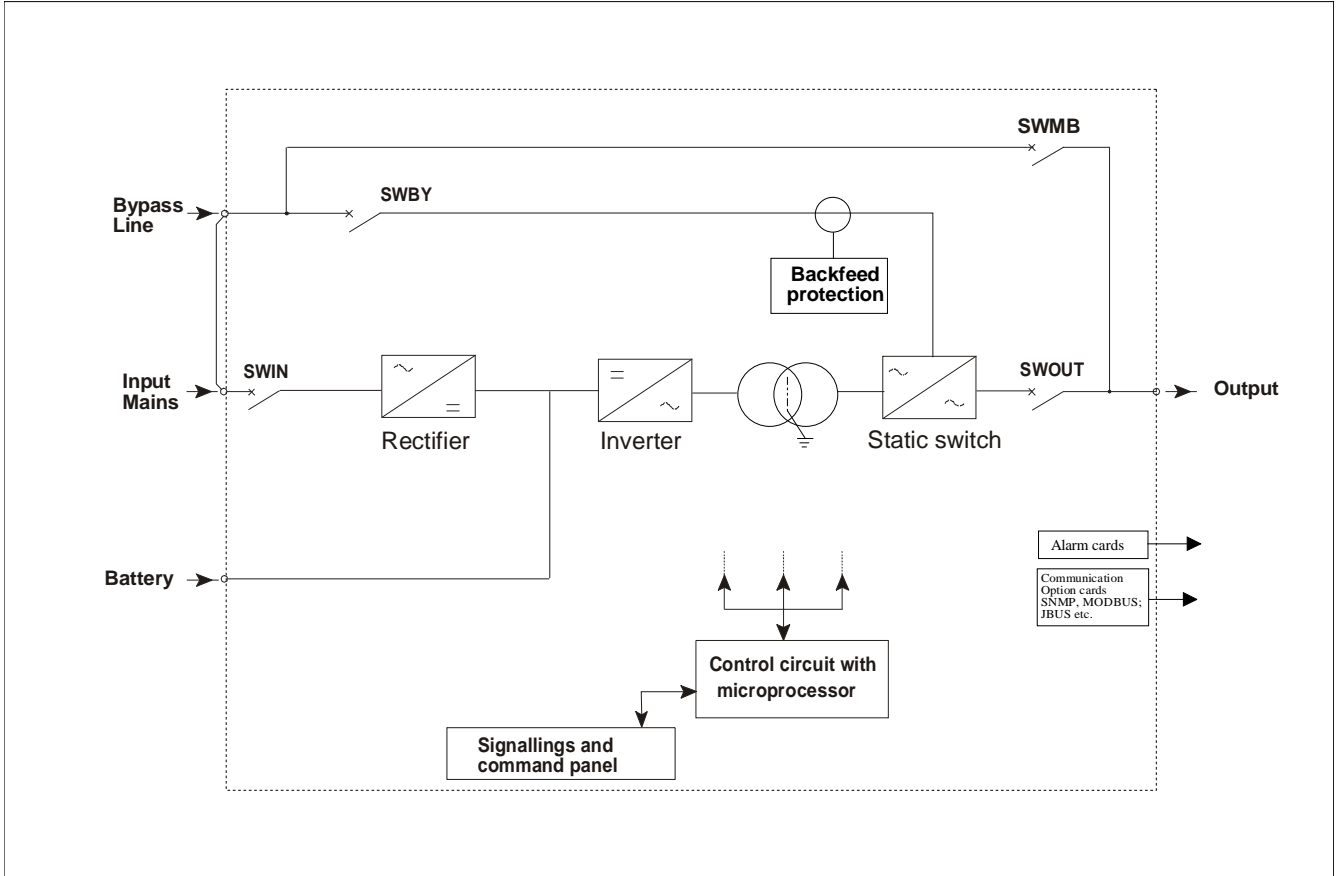

6.1. AC/DC Converter

The AC/DC Converter battery charger converts the alternating voltage into direct voltage to power the inverter at nominal load. Several versions of UPS, the HC, D, DHC, are available. These use various technologies at the input stage to reduce the current harmonics reflected to the mains up to 3% and increase the power factor up to 0.95 (see the Technical Data tables at the end of these specifications). This kind of Converter has two main functions:

6.1.1. Easy Source

MASTER MPS is designed in order to reduce at minimum the impact on the mains source or on the upstream Generator Set. In detail the features are as follow:

- **Input harmonics:** thanks to a low input harmonics content and the high power factor, the costs of installing and dimensioning a generator set upstream are greatly reduced.
- **Power Walk-in:** when the voltage is applied in input to the rectifier, for example after a mains power failure, the rectifier reaches nominal power progressively in a time programmable from 0 to 125 seconds.
- **Power Walk-in delay timer:** in parallel configurations, the start-up of the rectifiers can be delayed to reduce the impact to any generator located upstream. The delayed start-up is programmable up to 125 seconds.

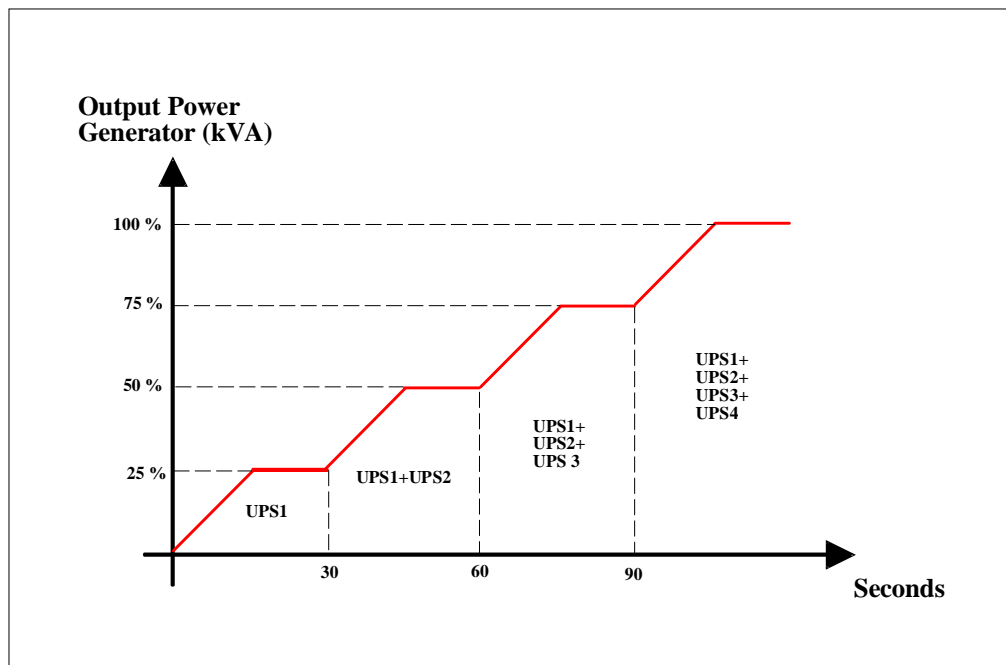

Example of calibrated start-up of the rectifiers in a parallel system

- **Inhibition of the battery charge current:** while the UPS is operating with a generator set, battery recharging can be excluded and all the available power used to feed the load.
- **Inhibition of the synchro with bypass:** in case of a generator set with the output frequency very unstable, the Inverter synchronization with bypass can be inhibited. In this condition the Inverter generates the output voltage in free running mode by using the internal oscillator and consequently the transfer of the load on bypass is not allowed.

The “battery recharge current” and “Inverter Synchro with bypass” inhibitions are activated by a remote contact of the generator set connected to the optional Rely Card (see Chapter 12 – Options)

6.1.2. Battery Care System

The “Battery Care System” is a set of functions designed to control, manage and preserve the battery for as long as possible.

- a) **Battery recharging:** this UPS product will work with hermetically-sealed lead (VRLA), AGM, open vase or Ni-Cd batteries. Depending on the type of battery, two recharging methods are available:
 - **Cyclical recharging (factory set):** the battery’s charge state is kept under constant control, so that when the charge level drops below the established level, a recharging cycle starts up following the IU characteristic (EN 50272-2). In any case, the UPS automatically runs a top-up charge cycle every 24 hours.
 - **Two-level recharging (configurable):** this recharge is carried out with limited current at two voltage levels following the IU₁ U₂ characteristic (EN 50272-2)) Charging in the first phase is at the rapid charge voltage (U₁), followed by a second phase at floating charge level (U₂). Both these recharge values are ensured with **recharge voltage temperature compensation** as required by the battery manufacturers so that battery life is not jeopardised. This type of recharge can be configured on-site and is mainly used with open vase and NiCd batteries.
- b) **Battery test:** in normal operating conditions the battery is checked automatically at regular intervals or on manual command. The test takes place without appreciably discharging the battery, in complete safety for the load and without compromising the battery service life. If the test has a negative outcome, a report signal will appear on the UPS panel and remotely.
- c) **Protection against slow discharges:** in the event of discharges of long duration and low load, the end of discharge voltage is raised to approx. 1.8 V/el as prescribed by the battery manufacturers so as to avoid damaging the batteries.
- d) **Current ripple:** in normal operating condition and with the battery charged, the current ripple is zero. This feature eliminates one of the main causes of reduced battery reliability.

6.2. DC/AC Converter

The DC/AC converter converts the direct voltage into stabilised, sinusoidal alternating voltage for the power supply of the load. With the UPS in ON-LINE mode, the load is always powered from the inverter.

This comprises a three phase inverter with IGBT (Isolated Gate Bipolar Transistor), a transistor that allows high switching frequencies (>20kHz) and consequently low consumption and low noise.

The inverter output is connected to the transformer, thus ensuring galvanic isolation between output and battery.

Voltage regulation

The output voltage is regulated by using the independent phase control, a feature that allows a better static and dynamic response. In detail:

- a) **static condition:** the inverter output voltage remains within $\pm 1\%$ for all input voltage variations within the allowed limits;
- b) **dynamic condition:** for load variations from 0 to 100%, the output voltage remains within $\pm 5\%$ below the values defined by class 1 of standard EN 62040-3.

Frequency regulation

The inverter output frequency is generated autonomously by an internal oscillator, in sync with that of the emergency mains; the frequency stability towards the load therefore depends on the operating condition:

- a) Frequency stability
 - a. With mains available: the internal oscillator follows the frequency variations of the emergency mains according to the set value, which is normally $\pm 2\%$ (can be calibrated from $\pm 1\%$ to $\pm 6\%$).
 - b. With mains not available: the inverter generates the output voltage frequency autonomously with a stability of $\pm 0.05\%$.

- b) Speed of frequency variation

The maximum speed of inverter output frequency variation to reach that of the emergency mains is 2Hz/s for the UPS in single version, and 1Hz/s for the parallel version.

Distortion of the output voltage

The regulation of the inverter guarantees the distortion of the output voltage with linear loads within 1% (max 2% with battery at end of discharge). With non linear loads, as defined by standard EN 62040-3, the distortion of the output voltage should not exceed 3%.

Output Power

The Inverter is designed to supply loads with power factors from 0.6 inductive to 0.5 capacitive. The nominal output power rating of the UPS is given with a power factor of 0.9 inductive.

Overload

The inverter is sized to supply a power overload (kVA) of 110% for 1 hour, 125% for 10 minutes and 150% for 1 minute, on the three phases. On two phases, the limit is 200% for 7 s.

If the time or power limits are exceeded, the load is transferred onto the emergency mains.

Short circuit capacity

In the event of a short circuit on the load and with power supply from the battery, the inverter can supply a current limited to 150% for 1 s in the event of a short circuit on the three phases, and 250% for 1 s in the presence of a short circuit between phase and neutral.

Symmetry of the output voltage

In all conditions, the symmetry of the output voltage is guaranteed within $\pm 1\%$ for loads balanced on the three phases, and $\pm 2\%$ for 100% unbalanced loads (e.g. one phase at nominal load, the other two without load).

Phase shift

The inverter three-phase output voltages are guaranteed with a phase shift angle of $120^\circ \pm 1^\circ$ for balanced loads and 100% unbalanced loads.

6.3. Static Switch

The Static Switch is an electronic device that transfers the load onto the emergency mains without any break in power in the following circumstances:

- a) manual shutdown of the inverter;
- b) exceeding of the inverter overload limits;
- c) exceeding of the internal over temperature limits;
- d) inverter fault;
- e) DC voltage outside the admitted range.

If at the time of switching the inverter voltage is not in sync with that of the emergency mains, the transfer takes place with a delay of approx. 20 ms to avoid possible damage to the load. However this value can be set from 10 to 100 ms to cover all the requirements of the various types of load.

Emergency mains voltage

Transfer onto the emergency mains only takes place if the voltage and frequency are considered “suitable” to power the load. The limits of acceptability are defined by the user in relation to the connected load:

- Voltage window: $\pm 10\%$ (can be calibrated from $\pm 5\%$ to $\pm 25\%$);
- Frequency window: ± 1 Hz (can be calibrated from ± 1 Hz to ± 6 Hz).

Overload

The Static switch is of the type that is “transparent” for the load, since it does not include the automatic overcurrent protection devices as required by most applications. The disconnecting devices are installed externally in accordance with the equipment’s selectivity characteristics.

The UPS Static switch is sized to support the following overloads.

- 110% for 60 minutes
- 125% for 10 minutes
- 150% for 1 minute

For the other values refer to the chapter “Technical Specification”.

7. CONTROL PANEL

The control panel located at the front of the equipment may be used to monitor and control all the parameters of the UPS and the batteries connected to it. The operating status of the UPS is shown on a liquid crystal display (LCD), with two rows of 40 characters and four LEDs with three operating states: On (steady), On (flashing), and Off.

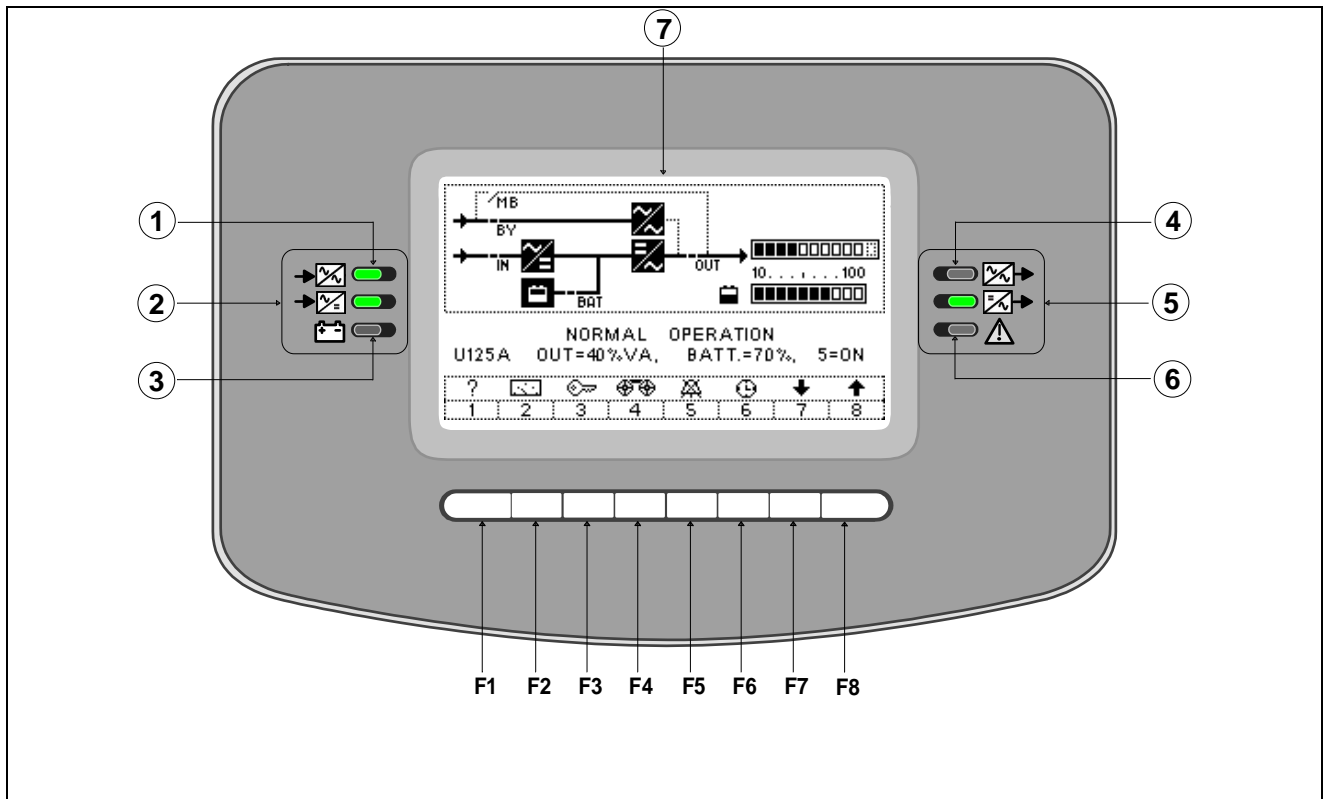

- | | |
|-----------------------------------|--------------------------------|
| ① LED Bypass input line indicator | ④ LED bypass output |
| ② LED Mains input line indicator | ⑤ LED Normal output |
| ③ LED Battery indicator | ⑥ LED Alarm for internal fault |
| | ⑦ Graphic display |

F1, F2, F3, F4, F5, F6, F7, F8: FUNCTION KEYS

The function of each key is shown at the bottom of the display screen and varies according to the menu displayed.

The display shows the event history log up to 120; the measurements and associated alarms are recorded for each event.

The messages are available in the following languages: Italian, English, French, German, Spanish, Portuguese, Dutch, Swedish, Polish, Hungarian, Turkish, Czech, Romanian and Russian (as options).

Measurements

- Input voltage and frequency
- By-pass voltage and frequency
- Input power
- Output voltage and frequency
- Output power
- Output power peak
- Battery voltage
- Battery recharge/discharge current
- Inverter input voltage
- Internal temperature (logic control, rectifier, Inverter, static switch and magnetic components)
- Sinewave view of the following signals :
 - Input Current /Output Current
 - Input Voltage/ Output Voltage

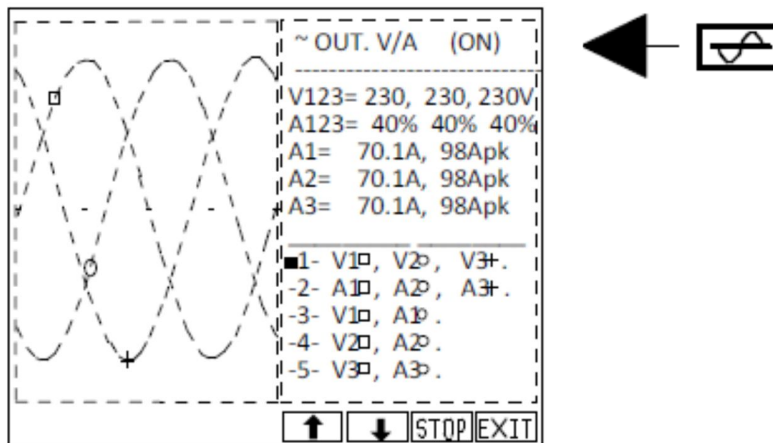

- Hours of operation on inverter
- Hours of operation on by-pass
- Hours of operation on battery
- Battery actuation time
- Number of complete battery discharges

Messages

The alarm messages are shown below:

<i>INTERFERENCE ON BYPASS LINE</i>	Presence of disturbances on the bypass line
<i>MANUAL BYPASS SWITCH CLOSED</i>	The manual bypass maintenance switch is closed.
<i>FAULTY BYPASS VOLTAGE OR SWBY, FSCR OFF</i>	The line voltage or frequency is outside the limits or the switch is open
<i>FAULTY POWER SUPPLY VOLTAGE OR SWIN OFF</i>	The rectifier power supply voltage is outside the limits or the rectifier is faulty.
<i>MINIMUM BATTERY BACK-UP TIME PREALARM</i>	The battery is discharging and has reached the minimum back-up time value (can be calibrated)
<i>BATTERY TEST FAILED OR BATTERY SWITCH OPEN</i>	The battery test has failed or the battery switch is open
<i>POWER SUPPLY VOLTAGE LOW</i>	The battery voltage is below the preset limit.
<i>OUTPUT OVERLOAD</i>	The load connected to the inverter has exceeded the nominal value in kVA.
<i>LOAD POWERED FROM BYPASS DUE TO MINIMUM LOAD</i>	When the load is less than the value set by the operator, it is transferred onto the bypass line.
<i>INTERNAL FAULT NUMBER</i>	Internal fault, details of the alarm are provided by a code.

<i>LOAD TEMPORARILY ON BYPASS</i>	The load is temporarily on the bypass due to inrush current or inverter start-up.
<i>LOAD ON BYPASS DUE TO OUTPUT OVERLOAD</i>	Load on bypass due to exceeding of the inverter overload limits
<i>BYPASS COMMAND ACTIVE</i>	Load forced onto bypass
<i>REMOTE COMMAND FOR BYPASS: ACTIVE</i>	Load forced onto bypass by remote command
<i>OVERTEMPERATURE OR VENTILATION FAULT</i>	The temperature inside the cabinet has exceeded the maximum limit due to too high ambient temperature or ventilation fault.
<i>FAULTY INPUT PHASE SEQUENCE</i>	Indicates that the sequence of the phases to the input is faulty.
<i>NO OUTPUT VOLTAGE</i>	Alarm when the output voltage is not present since SWOUT and SWMB are both open at the same time.
<i>AUTO-OFF TIMER: TOFF= 0: 0', TON= 0: 0'</i>	Setting of the date and time of automatic UPS start-up and shutdown

8. SWITCHES

The system is provided with four disconnecting switches under load located face on the cabinet whose access is by opening the door:

- SWIN Rectifier input
- SWBY Emergency mains input
- SWOUT Load output
- SWMB Maintenance bypass.

The battery switch is placed in the battery cabinet or in a wall panel.

9. COMMUNICATION

The alarms, commands and the communication software supplied together with the UPS to interface the unit with the system are listed below.

If these are not sufficient, please see the Options chapter.

Two DB9 connectors are available for RS232 connection; the outputs can be connected to a remote computer or to a modem.

9.1. Report signals

These are provided by means of voltage-free relay contacts. The maximum capacity of the contacts is 1A – 250V (max):

- Battery low
- Battery discharging
- Load on bypass or UPS fault.

9.2. Commands

The following commands in the UPS can be activated by means of an external voltage at + 12V, 80mA (max):

- Inverter ON/OFF (or “battery recharge inhibition” by means of a setting from the UPS panel)
- Complete shutdown of the UPS.

9.3. Emergency shutdown

In the event of an emergency the UPS can be completely shut down by an external command.

9.4. Monitoring and control software

The system is provided with Powershield³ monitoring and control software with the following features:

- Event chronology
- Total events management
- E-mail, modem, SNMP Agent support
- Sequential shutdown of all the PCs in the network, saving the active work of the most varied applications.

10. UPS CABINET

The cabinet is made of galvanised steel with IP20 degree of protection even with the front door open.

For MPT 10 kVA up to 80 kVA and MPM from 10 up to 80 kVA the forced ventilation is ensured by means of fans at the back; air intake is from the front, and output is from the back.

For MPM 100 kVA the forced ventilation is ensured by means of fans at the top; air intake is from the front, and output is from the top.

The parts with greater dissipation, such as the power modules and magnetic parts, are monitored by temperature sensors.

11. INSTALLATION

The systems are designed to allow all ordinary and extraordinary maintenance operations from the front, thus making back or side access superfluous; the cables input is from the bottom. The cables input can optionally be from the top.

Pallet lifters may be used to move the systems.

12. OPTIONS

12.1. Communication

Software

PowerNETguard is a centralised UPS management program which operates by means of the SNMP communication protocol. It is an ideal tool for a Data Centre EDP manager or in medium and large scale networks.

The main features are set out below:

- Display at various levels of geographical areas, building plans, maps;
- Multi-user accesses with several levels of safety;
- Compatible with standard RFC 1628 SNMP agents;
- Creation of graphics and saving on file for physical input and output values;
- Notification of alarms via e-mail and SMS;
- Integrated Wap Server for the display of alarms;
- Suitable for operation with Windows operating systems: (98, ME, NT, 2000, 2003, and Xp) Linux, Mac OS X, Solaris 8 and 9.

Hardware

Two slots are available inside the device, at the bottom, to house two of the following communication options:

- a) **NetMan 102 Plus:** Network agent for the management of the UPS connected directly on LAN 10/100Mbps using the main network communication protocols (TCP/IP, HTTP and SNMP). A MODEM can also be connected to the same device.
- b) **Netman 202 Plus:** network agent like Netman 102 Plus, but improved with USB host, SNMP v1 and v3, maximum expandability and firmware upgradeable via USB port FTP and http
- c) **MultiCom 302:** Modbus/Jbus protocol converter by means of RS232 or RS485 output for the monitoring of UPSs in BMS (Build Management System). It also manages a second independent RS232 serial line that can be used to connect other devices such as NetMan Plus or a PC.
- d) **MultiCom 352:** a device that makes it possible to connect two devices to a single UPS serial port. It can be used in all cases where several serial connections are required for multiple interrogation of the UPS.

The communication cards can be used simultaneously in various combinations to achieve greater flexibility and therefore enhanced services, as can be seen in the following example:

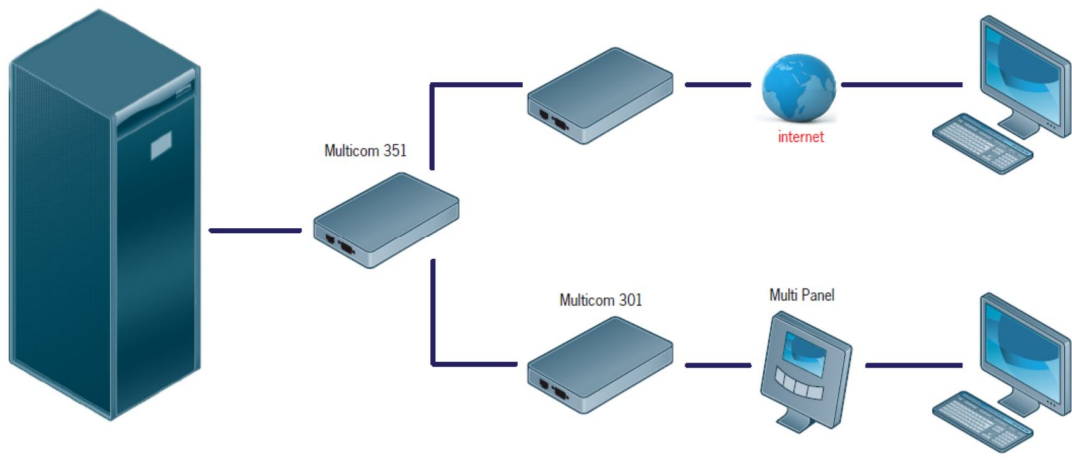

Netman 101

In addition to the cards above mentioned the following communication options are available:

e) **Programmable relay contact PCB** (5A-250V) for connecting a remote control device. The following default alarm signals are available:

- a. Load on Inverter;
- b. Load on mains power;
- c. Low battery;
- d. Overload;
- e. Over temperature;
- f. Load on maintenance by-pass.

When necessary, the meaning of the above alarms may be changed, choosing from amongst the alarms listed in the following table.

ALARMS	DESCRIPTION
<i>INTERFERENCE ON BYPASS LINE</i>	Disturbance on the bypass line (e.g. voltage peaks, harmonic distortion etc.) while the voltage and frequency values remain within acceptable limits. The inverter is not synchronized with the mains power supply.
<i>MANUAL BY-PASS, SWMB-OFF</i>	The SWMB manual bypass switch is closed.
<i>FAULTY BY-PASS VOLTAGE or SWBY, FSCR OFF</i>	Alarm status present if the voltage at the input of the bypass line is incorrect or the SWBY bypass switch is open.
<i>FAULTY MAINS SUPPLY VOLTAGE or SWIN OFF</i>	The voltage supplied to the rectifier is incorrect or the SWIN switch is open. The battery is in discharge mode.
<i>PRE-ALLARM FOR LOW BATTERY VOLTAGE</i>	The battery voltage is lower than the value calculated to give around 5 minutes back up power; the pre-alarm value is settable
<i>BATTERY DEPLETED or (SWB BATTERY SWITCH OPEN</i>	The battery test has encountered a problem.
<i>LOW POWER VOLTAGE or OVERLOAD</i>	The power voltage is lower than the nominal value or there is an output overload.
<i>OVERLOAD ON OUTPUT</i>	The inverter is in overload status.
<i>BY-PASS FOR OUTPUT VA < AUTO_OFF VALUE</i>	This alarm indicates that the power expressed in % VA, absorbed by the load is lower than the "AUTOOFF" value (function to be activated when the system is powered up).
<i>INTERNAL FAULT: code number</i>	Code of the internal anomaly condition.
<i>TEMPORARY BY-PASS, WAIT</i>	The load is powered temporarily by the bypass line (e.g. for transitory current peaks).
<i>BY-PASS FOR OVERLOAD ON OUTPUT</i>	The load is powered by the bypass line for overloads on the inverter in excess of the set limits.
<i>BY-PASS COMMAND ACTIV; 8=OFF</i>	This alarm indicates when the load is forced over to the bypass line using a command on the front panel. The inverter is switched off.
<i>REMOTE BYPASS COMMAND: ON 8=OFF</i>	This alarm indicates when the load is forced over to the bypass line via a remote command. The inverter is switched off.
<i>OVERTEMPERATURE or FAULT ON FANS</i>	This alarm indicates an internal over temperature caused by an increase in environment temperature outside the set limits or due to malfunctioning of the fans.
<i>FAULTY INPUT PHASE SEQUENCE</i>	The input phase sequence at the input of the bypass line is incorrect.

SWOUT AND SWMB OPEN	This alarm indicates when there is no output voltage due to the simultaneous opening of the SWOUT output switch and the SWMB manual bypass switch.
SHUTDOWN COMMAND: ACTIVE; 8= OFF	This alarm indicates when the shutdown command (Rectifier+Inverter+CS) has been activated on the front panel or through the connection of the RS232 interface (Powershield ³).
REMOTE SHUTDOWN COMMAND: ON 8=OFF	This alarm indicates when the shutdown command (Rectifier+Inverter+CS) has been activated via remote contact.
CHANGE MEMORY: CODE = number	Indicates that the system settings have been changed
BATTERY OVERTEMPERATURE	The temperature of the battery compartment has exceeded the set limits.
BATTERY TEST FAILED	The battery test has encountered a battery fault.
FAULTY FANS ALARM	This alarm indicates a faulty fan inside the system (optional function - on request).
FUSE FAULT	This alarm indicates one or more faulty fuses inside the system (optional function - on request).
FAULT ON PARALLEL CONNECTION	The parallel connection has been interrupted or is disconnected
AUTO-OFF Timer: Toff= 0: 0', Ton= 0: 0'	This alarm indicates when the shutdown command (Rectifier+Inverter+CS) has been activated via remote contact.

There are two programmable input default settings to “inhibit battery charging” and “inhibit the bypass” which can be used with a gen set; a voltage free contact is all that is required to activate the functions.

When required, the function of the two inputs can be changed as follows:

- i. External switch auxiliary contact
- ii. Setting the UPS in STAND-BY-ON
- iii. Start/stop of the battery test
- iv. Start up/shutdown of the Rectifier (battery discharge).

N.B.: the UPS systems are designed to house two alarm PCBs, thus obtaining up to 12 programmable alarms and 4 inputs.

- f) **Multicom 401 (Profibus Converter)** is an accessory, external to the UPS, which makes it possible to integrate the UPS in a network which uses the Profibus DP communication protocol.
- g) **Multi I/O PCB:** an accessory mounted inside the UPS that converts external signals from the UPS (e.g. ambient temperature, battery room temperature, etc.) into signals by means of relay contacts or on an RS485 serial output in MODBUS protocol.

For the full and updated list of accessories please see the website www.riello-ups.com

12.2. Graphic remote panel

Graphic remote panel gets available remotely on the Graphic Display the information on the UPS status, the measurements and the alarms. In addition it is fitted a RS485 port which gets available the same information in JBUS/MODBUS protocol for the BMS.

The max distance between the UPS and remote panel is approx 300 mt.



12.3. Battery cabinets

Battery cabinets in the same style as the UPS are available with the following features:

- protection fuse and switches;
- IP20 level of protection with front door open;
- complete with battery or empty with connection cables between the cells.

The models are:

UPS from 10 to 100 kVA

- Battery Cabinet 32x38 Ah – Dimensions (WxDxH) 555x740x1400 mm
- Battery Cabinet 32x65 Ah – Dimensions (WxDxH) 860x740x1400 mm
- Battery Cabinet 32x80Ah – Dimensions (WxDxH) 860x740x1400 mm
- Battery Cabinet 32x120Ah – Dimensions i (WxDxH) 860x740x1400 mm

The battery modules can be connected in parallel to achieve the required availability. If more than 2 modules are connected in parallel, the addition of a module with a single circuit breaker for the parallel connection cables is recommended. An example of the installation is shown in the figure below.

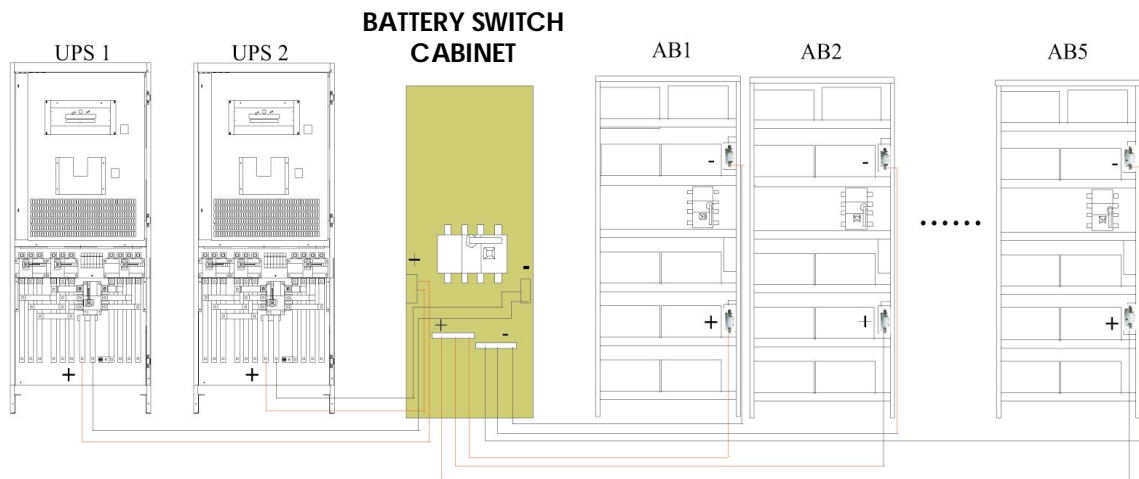

12.4. Start-up from battery (Cold Start)

This device makes it possible to switch on the UPS even in the event of a mains failure using only the battery energy.

12.5. UGS - UPS Group Synchroniser

This allows 2 systems connected in a “**DUAL BUS**” configuration to keep synchronised with each other for any variation in the mains voltage, including total failure. The UGS also allows a RIELLO UPS to be synchronised with another power source or to an independent non RIELLO UPS system, even one of a different power rating.

The UGS box is designed to be wall-mounted:

- Dimensions (WxDxH): 150x70x110 mm;
- Weight: 2Kg.

12.6. PSJ - Parallel Systems Joiner

This allows two UPS units to be connected in parallel, with the system on (without interrupting output) by means of a power coupling switch in accordance with the system indicated in Chapter 4.

The PSJ box is designed to be wall-mounted:

- Dimensions (WxDxH): 300x220x120 mm;
- Weight: 2Kg.

12.7. Isolation transformers

The UPSs of the MASTER MPS series, in standard configuration are equipped with an output isolation transformer on the inverter and, for that reason, they are classified as Transformer Based UPSs. In the standard configuration the load is isolated from the inverter and from the battery. Wherever it is necessary to isolate the load from the input when the UPS is in Bypass Mode or to create the input neutral, external cabinets with a delta/star bypass isolation transformer are available.

In case of installations with external maintenance bypass, please contact the sales department.

12.8. Kit for UPSs without input and output neutral

Normally the UPS requires the neutral in input to operate correctly. In applications where the neutral is not available in input and is not required in output, a dummy neutral can be created using this kit.

This device is used only for reference to the internal logic and not for the supply of power.

12.9. Protection levels

The units can be provided with levels of cabinet protection over IP20 in accordance with standard EN 60529.

12.10 Faulty fan control

In addition to the standard internal temperature control, the **MASTER MPS** series can also be fitted with a device for controlling the operation of each individual fan. In the event of a fault, an alarm shows on the front panel of the system via relay contacts and software

13. ENVIRONMENTAL REQUIREMENTS

- Ambient temperature for the UPS 0 to 40° C
- Maximum temperature for 8 hours a day 40° C
- Average temperature for 24h 35° C
- Recommended temperature for the batteries: 20 to 30° C
- Humidity < 95 % (without condensing)
- Maximum operating altitude up to 1000 m ASL.
(1,5 % of derating each 100 m between 1000 and 4000 m)

- Storage temperature - 25° up to 70 °C (UPS)
-20-30 °C (for battery)

14. TECHNICAL DATA THREE PHASE INPUT / THREE PHASE OUTPUT

Mechanical features	Potenza UPS (kVA)						
	10	15	20	30	40	60	80
Dimensions - Width [mm] MPT							
6 Pulse - with internal batteries (A12+A12 or above)	555			Not available			
6 Pulse - without internal batteries	555					800	
6 Pulse - With Filter (without internal batteries)	825					1070	
12 Pulse - without internal batteries	Not available					1070	
12 Pulse - With Filter (without internal batteries)	Not available					1070	
Depth [mm]	740						
Height [mm]	1400						
Weight (Kg)							
• 6 Pulse	200	220	275	315	340	440	520
• 12 Pulse						630	650
Ventilation	Forced by internal fans						
Output Air	From the rear						
Protection Degree	IP20 (on request above protection degree)						
Input Cable	From the bottom						
Colour	RAL 7016 (dark grey)						

Electrical Data	UPS POWER (kVA)						
	10	15	20	30	40	60	80
INPUT							
Rated voltage	400 Vca 3phase						
Rated voltage tolerance (a 400 V) With battery in charge	+20% , - 25% (see note 1)						
Rated voltage tolerance with Battery in charge	+ 20% , - 10%						
Rated voltage tolerance without Battery in charge	+ 20% , - 20%						
Input frequency tolerance	From 45 to 65 Hz						
Power at nominal current and nominal voltage (400 V) - kVA							
• 6 Pulse	11	16	22	32	43	64	84
Max. Power at nominal load, nominal voltage and battery in charge (kVA)							
• 6 Pulse	15	23	31	46	62	92	123
Max. Current at nominal load, nominal voltage and battery in charge (A).							
• 6 Pulse	22	34	45	65	87	131	175
Harmonic Distortion (THDi) and power Factor at full load, nominal voltage (400 V) and battery charged (see Note 2)							
• 6 Pulse	25% THDi , 0,9 Pf						
• 6 Pulse + Filter	5% THDi , 0,9 Pf						
• 12 Pulse						5% THDi, 0,93 Pf	
• 12 Pulse + Filter						3% THDi, 0,95 Pf	
Progressive starting of rectifier (power walk-in 0-100%)	from 0 to 125 seconds (settable)						
Delay of progressive start of rectifier (Power Walk-in delay timer)	from 0 to 125 seconds (settable)						

Electrical data	UPS POWER (kVA)						
	10	15	20	30	40	60	80
INTERMEDIATE CIRCUIT							
Number of Lead Acid elements (see note 3)	192						
Float voltage (2,26 V/el. , can be calibrated) – Vdc	434						
Recharge Voltage (2,4 V/el. , can be calibrated) – Vdc	460						
Maximum output voltage (Vcc)	500						
End of discharge voltage Vcc (1,6 V/el, can be calibrated)	306						
Ripple voltage with recharged battery (%)	Approx. 0						
Charging current (A)							
• Full load	2	3	4	6	8	12	16
• Load 90%	5	7	9	13	18	26	36
• Load 80%	7	11	14	21	27	41	56
• Load ≤ 50%	15	18	29	37	37	75	75
INVERTER							
Rated Power Pf 0.9 inductive (kVA)	10	15	20	30	40	60	80
Active Power with Pf 1 (KW)	9	13.5	18	27	36	54	72
Nominal Voltage	400 Vca 3 phase + N (settable from 380 V to 415 V)						
Nominal Frequency	50 o 60 Hz (settable)						

Electrical Data	UPS POWER (kVA)						
	10	15	20	30	40	60	80
Output voltage regulation	from 360 a 420V						
Static variation	± 1%						
Dynamic variation	± 5%						
Recovery time within ± 1%	20ms According to the standard EN 62040-3, class 1						
Crest current factor (I _{peak} /I _{rms} according the standard EN 62040-3)	3:1						
Voltage distortion with linear load	1% (typical), 2% (max)						
Voltage distortion with non linear load (EN 62040-3)	< 3%						
Frequency stability with inverter not synchronized to the by-pass mains.	± 0,05%						
Speed of frequency variation	1 Hz/sec (settable from 0,1 to 3 – see note 4)						
Overload referred to the nominal power	110% for 60 minutes, 125% for 10 minutes, 150% for 1 minute						
Short circuit Current <ul style="list-style-type: none"> Phase/ Neutral 	280% for 1 second in current limitation						
Inverter efficiency (%)	94%						

Electrical data	UPS POWER (kVA)						
	10	15	20	30	40	60	80
BY-PASS							
Nominal voltage	400 Vca single phase (settable from 380 V to 415 V)						
Nominal voltage tolerance	± 20% (can be regulated from ± 5 % to ± 25% from the control panel)						
Nominal frequency	50 o 60Hz (autosensing)						
Frequency tolerance	2% (can be regulated from ± 1% up to a ± 6% from the control panel)						
Switching onto by-pass with Inverter synchronized (UPS in "Normal Mode")	Approx 0 ms						
Switching onto by-pass with non-synchronized Inverter (UPS in "Normal Mode")	20 ms						
Switching from by-pass to Inverter (UPS in "Stand-by On mode")	From 2 to 5 ms						
Delay in transferring to Inverter after the switching onto by-pass	4 sec						
Overload Capacity of by-pass line (kVA)	110 % for 60 minutes, 125 % for 10 minutes, 150 % for 1 minute						
Short circuit capacity of by-pass line (x nominal voltage) I/In							
• 1 second	7	4,6	3,5	5	7	7	7,5
• 100 ms	8	5	4	7	9	9	9
• 10 ms	12	8	6	8	12	12	14

Electrical Data	UPS POWER (kVA)						
	10	15	20	30	40	60	80
SYSTEM							
Neutral Sizing I/In	2	1,5	1.1	1.45	1.6	1.4	1.3
AC/AC Efficiency UPS 6Pulse (On line), Nominal Voltage and power factor 1 - (%)							
• Full Load	90,5	90,5	91,0	92,0	92,0	92,0	92,0
• Load 75 %	89,0	89,0	90	92,0	92,0	92,0	92,0
• Load 50 %	87,0	87,0	88,0	91,0	91,0	92,0	92,0
• Load 25 %	80,0	80,0	81,0	86,0	86,5	86,5	86,5
Efficiency with UPS in STAND-BY mode	98 %						
Dissipated power without load (kW) (see note 5) • 6Pulse and 6 Pulse + F	0.58	0.83	1.1	0.81	0.87	1.5	1.88
Dissipated power at full load • 6Pulse and 6 Pulse + F							
• kW	0,95	1.4	1.78	2.35	3.13	4,70	6.26
• Kcal/h	0,81	1,20	1,53	2,02	2,70	4,04	5,38
• BTU/H (5)	3220	4780	6100	8020	10700	16000	21380
Maximum current dispersion	500 mA max						
Noise level at 1m from the front (from 0 to full load) - (dBA)	60	60	60		62		

15. TECHNICAL DATA THREE PHASE INPUT/ SINGLE PHASE OUTPUT

Mechanical features	Power UPS (kVA)							
	10	15	20	30	40	60	80	100
Dimensions Width [mm] MPS								
6 Pulse - with internal batteries (A12+A12 or above)	555			Non applicable				
6 Pulse - without internal batteries	555				800			
6 Pulse - Width [mm]+ Filter (without internal batteries)	555		825		1070			
Depth [mm]	740						800	
Height [mm]	1400						1900	
Weight (Kg)								
6 Pulse	200	220	230	290	340	440	520	650
Ventilation	Forced by internal fans							
Output Air	From the rear						From the top	
Protection Degree	IP20 (on request above protection degree)							
Input Cable	From the low							
Colour	RAL 7016 (dark grey)							

Electrical Data	UPS POWER (kVA)							
	10	15	20	30	40	60	80	100
INPUT								
Rated voltage	400 Vca 3phase							
Rated voltage tolerance (a 400V)	+20% , - 25% (see note 1)							
Rated voltage tolerance with Battery in charge	+ 20% , - 15%							
Input frequency tolerance	From 45 to 65 Hz							
Power at nominal current and nominal voltage (400V) - kVA								
<ul style="list-style-type: none"> 6 Pulse 	11	16	22	32	43	64	86	105
Max. Power at nominal load, nominal voltage and battery in charge (kVA)								
<ul style="list-style-type: none"> 6 Pulse 	15	23	31	46	62	92	123	154
Max. Current at nominal load, nominal voltage and battery in charge (A).								
<ul style="list-style-type: none"> 6 Pulse 	22	33	45	67	89	134	178	220
Harmonic Distortion (THDi) and power Factor at full load, nominal voltage (400V) and battery charged (see Note 2)								
<ul style="list-style-type: none"> 6 Pulse 	25% THDi , 0,9 Pf							
<ul style="list-style-type: none"> 6 Pulse + Filter 	5% THDi , 0,9 Pf							
Progressive starting of rectifier (power walk-in 0-100%)	from 0 to 120 seconds (settable)							
Delay of progressive start of rectifier (Power Walk-in delay timer)	from 0 to 120 seconds (settable)							

Electrical data	UPS POWER (kVA)							
	10	15	20	30	40	60	80	100
INTERMEDIATE CIRCUIT								
Number of Lead Acid elements (see note 3)	192							198
Float voltage (2,26 V/el. , can be calibrated) – Vdc	434							447
Recharge Voltage (2,4 V/el. , can be calibrated) – Vdc	460							475
Maximum output voltage (Vcc)	500							500
End of discharge voltage Vcc (1,6 V/el, can be calibrated)	307							316
Ripple voltage with recharged battery (%)	Approx. 0							
Charging current (A)								
• Full load	2	3	4	6	8	12	16	24
• Load 90%	5	7	9	13	18	26	36	42
• Load 80%	7	11	14	21	27	41	56	61
• Load \leq 50%	15	18	29	37	37	75	75	110
INVERTER								
Rated Power Pf 0.9 inductive (kVA)	10	15	20	30	40	60	80	100
Active Power with Pf 1 (KW)	9	13.5	18	27	36	54	72	90
Nominal Voltage	230Vca single phase (settable from 220V to 240V)							
Nominal Frequency	50 o 60Hz (settable)							

Electrical Data	UPS POWER (kVA)							
	10	15	20	30	40	60	80	100
Output voltage regulation	for 210 to 242V							
Static variation	± 1%							
Dynamic variation	± 5%							
Recovery time within ± 1%	20ms According to the standard EN 62040-3, class 1							
Crest current factor (I _{peak} /I _{rms} according the standard EN 62040-3)	3:1							
Voltage distortion with linear load	1% (typical), 2% (max)							
Voltage distortion with non linear load (EN 62040-3)	< 3%							
Frequency stability with inverter not synchronized to the by-pass mains.	± 0,05%							
Speed of frequency variation	1Hz/sec (settable from 0,1 to 3 – see note 4)							
Overload referred to the nominal power	110% for 60 minutes, 125% for 10 minutes, 150% for 1 minute							
Short circuit Current	250% for 1 second in current limitation							
Inverter efficiency (%)	95%							

Electrical data	UPS POWER (kVA)							
	10	15	20	30	40	60	80	100
BY-PASS								
Nominal voltage	230Vca single phase (settable from 220V to 240V)							
Nominal voltage tolerance	± 15% (can be regulated from ± 5 % to ± 25% from the control panel)							
Nominal frequency	50 o 60Hz (autosensing)							
Frequency tolerance	2% (can be regulated from ± 1% up to a ± 6% from the control panel)							
Switching onto by-pass with Inverter synchronized (UPS in "Normal Mode")	Approx 0ms							
Switching onto by-pass with non-synchronized Inverter (UPS in "Normal Mode")	20ms							
Switching from by-pass to Inverter (UPS in "Stand-by On mode")	from 2 to 5ms							
Delay in transferring to Inverter after the switching onto by-pass	4 sec							
Overload Capacity of by-pass line (kVA)	110 % per 60 minutes, 125 % per 10 minutes, 150 % per 1 minute							
Short circuit capacity of by-pass line (x nominal voltage) I/In								
• 1 second	12	8	6	5	4	8	9	15
• 100 ms	16	10	8	8	6	11	14	21
• 10 ms	24	16	12	10	8	16	20	31

Electrical Data	UPS POWER (kVA)							
	10	15	20	30	40	60	80	100
SYSTEM								
AC/AC Efficiency UPS 6Pulse (On line), Nominal Voltage and power factor 1 - (%)								
• Full Load	92.0	92.0	92.0	92.0	92.0	92.0	92.5	92.5
• Load 75 %	91.5	91.5	91.5	92.0	92.0	92.0	92.0	92.0
• Load 50 %	91.5	91.5	91.5	92.0	92.0	92.0	92.0	92.0
• Load 25 %	89.0	89.0	89.0	92.0	89.0	89.0	89.0	89.0
Efficiency with UPS in STAND-BY mode	98 %							
Dissipated power without load (kW) (see note 5) • 6Pulse and 6 Pulse + F	0,22	0,32	0,43	0,65	0,86	1,29	1,72	2.15
Dissipated power at full load • 6Pulse and 6 Pulse + F								
• kW	0,78	1,17	1,56	2,35	3,13	4,70	5,84	7,30
• Kcal/h	0,67	1,01	1,35	2,02	2,69	4,04	5,02	6,28
• BTU/H (5)	2672	4008	5344	8016	10688	16032	19932	24914
Maximum current dispersion	500 mA max							
Noise level at 1m from the front (from 0 to full load) - (dBA)	60	62				62		63

Note:

- (1) With Input voltage -25 %, the battery doesn't charge and doesn't discharge.
- (2) UPS configured with battery charging in cyclic way (factory fitted)
- (3) The number of Pb elements accepted: 186 – 198
- (4) The parallel version can be calibrated from 0.1 to 1Hz/s.
- (5) 3,97 BTU = 1kcal.



RPS SpA – *Riello Power Solutions*
Viale Europa, 7
37045 Legnago (VR)-Italy
e-mail: riello@riello-ups.com
www.riello-ups.com